

FJ



FUSO



Built for Maximum Profitability

- Lower operating cost, maximizes profitability
- Versatile, high-performance engines are more fuel-efficient
- Aerodynamic cab design saves fuel and reduces cabin noise
- Tough, durable chassis and suspension allow heavier loads
- Smooth-shifting transmission and intelligent instrument panel enhance drivability
- Safe, comfortable cabins with bunks and plenty of storage space
- Anti-roll bars for greater safety and stability
- Longer service intervals and service you can count on

Actual vehicle may differ slightly from pictures shown

Delivering Profit for the Heavier Load

Sleeper cabin with bunk



Fuel-efficient engine with high output, flat torque and greater durability.

Aerodynamic cab design more fuel-efficient and quieter at high speeds

Front anti-roll bar to improve stability is standard equipment

Smooth shifting 9 speed transmission enhances driving performance.

Fully adjustable seats and steering wheel for best driving posture



Delivering Profit on Every Site

Extended day cab with fold-down bunk



Higher horsepower engine for added muscle

9 Speed transmission with crawler gear for gradeability

Extra heavy duty bogie type rear suspension and rear axle for heavier loads

Standard front and rear anti-roll bars enhance stability.

Transmission power take-off (PTO) and differential lock as standard.



The Power You Need, the Durability You Count on

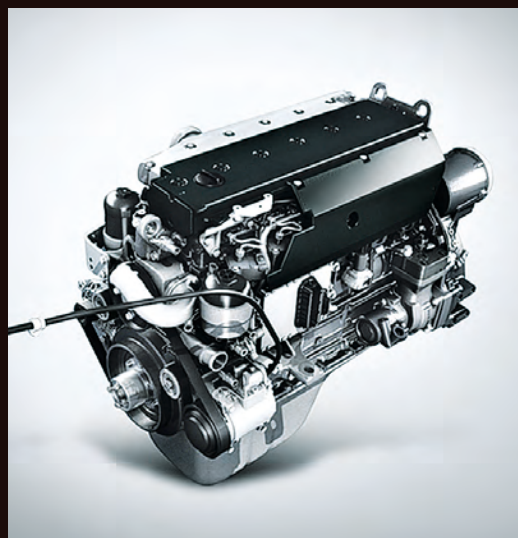

Engines of Profitability

FJ engines are durable and fuel efficient. The oil-lubricated fuel pump and lower engine speed reduce wear, increasing reliability, while unit fuel injectors and higher boost pressure on the turbocharger ensure complete burning of fuel.

6S20

DIESEL 6.4L

205kW

/2,200rpm

1,100Nm

/1,200-1,600rpm

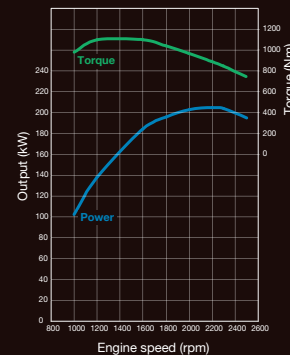

Smoothing the Way to Business Success

FJ trucks are equipped with 9 speed transmissions designed for smoother operation, to enhance driving performance and improve turnaround time.

Putting Your Business on a Firm Foundation

The frame members in the chassis are not only deeper and thicker but also shot peened and powder coated for greater surface strength and resistance to corrosion. Transmission gears, clutch pads and brakes are all extra-thick for greater durability.

Keeping Your Work Moving Forward

Standard on models designed for tipper operations and optional on other models, the differential lock overcomes wheel spinning and makes truck easier to operate in slushy/bogged down conditions.

With Everything on an Even Keel

Anti-roll bars, standard both front and back in models designed for tipper applications (rear anti-roll bar optional in other models), combine with wider wheel track to ensure vehicle stability when the center of gravity is high.

Making Light Work of Heavy Loads

In FUSO trucks, Multi-leaf balancer type rear suspension in FJ Rigid and bogie type rear suspension in FJ Tipper for longer life and heavier loads.

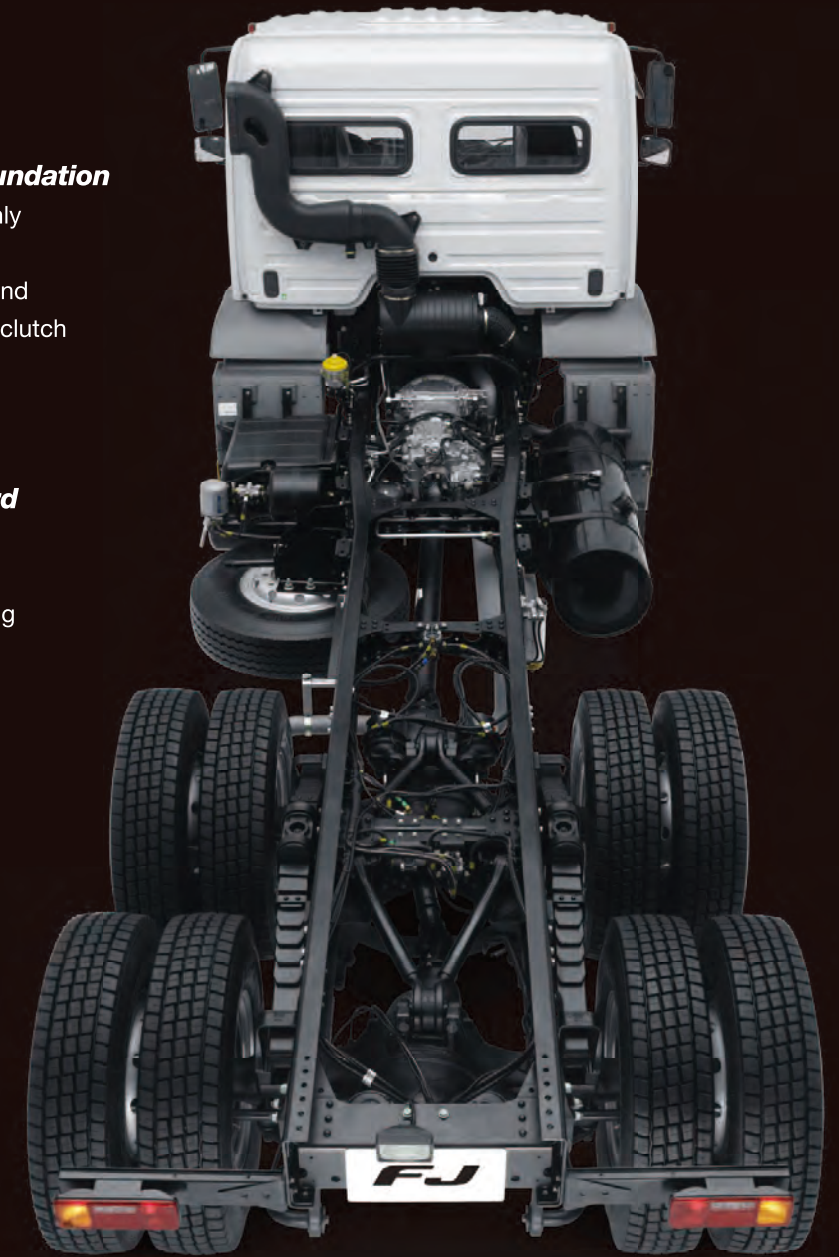

Rigid

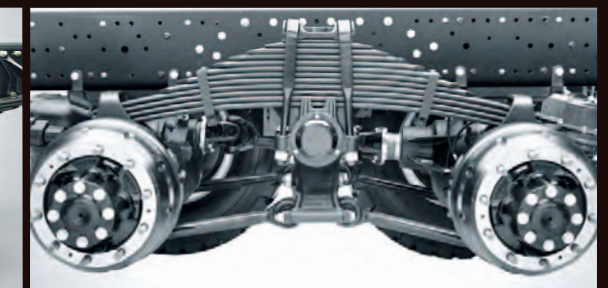

Tipper

Long Days, Hard Days, Drivers Need Help



Convenient overhead console box.

Introducing the Better, More Comfortable Workplace

The seats are fully adjustable. Add the tilt-and-telescoping steering wheel. Drivers of FJ trucks can choose the postures that suit them best. Look around. The lined roofs and side trim are a nice touch. But the extra storage close to hand? That's invaluable.



A Smarter Place to Work

The LED in the center of the intelligent instrument cluster makes all vital information available at a glance. That information includes the Trip Mileage Indicator, which shows average fuel consumption, how far the truck has traveled, and how much fuel has been consumed.



Making It Simple to Stay in the Zone

Variable Green band light glows to warn driver if driving at high rpm in low gear or low rpm in high gear. Shifting to appropriate torque saves fuel and reduces engine and power train wear.



You Could Really Enjoy This Drive

Footsteps and climbing grips, combined with a wider opening door, make it easier to get in and out. The rear windows can be opened to increase ventilation or closed to reduce noise. The blower to keep the air moving is standard. Air conditioning is an option.

Every Business Needs a Safe Investment



Front Proximity Mirror

Mounted on roof. Improves handling by showing driver what is directly below the front of the truck.



Brakes You Can Depend on

The brakes on FJ trucks have wider, thicker brake linings. They not only improve braking performance but also last longer as well, making possible longer intervals between regular maintenance.



A Safer Standard

Front anti-roll bars are standard equipment built into the front suspension of every FJ truck. Combined with wider wheel track, they contribute to vehicle stability even in extreme driving conditions.



Even Safer

Rear anti-roll bars are standard equipment on models designed for construction applications, optional but highly recommended on other models, especially when carrying taller cargo with higher centers of gravity.

Every Component is Proven Technology

Every component is proven technology that has survived over 11 million kilometers on the test track and been proven in use worldwide.

The Reliable Service You Need

Service combining state-of-the-art digital technology with highly trained mechanics is available from your FUSO dealer.



Every Truck Must Pass Through All Quality Gates

FUSO trucks are built at a state-of-the-art manufacturing facility, which also trains our service personnel. They are rigorously inspected at every step of the manufacturing process.